

# BRASS CHECK VALVE

## Ref. 303/305

Ref. : DS 303

Rev. : 1

Date : 08/06



valves and fittings

90 rue du ruisseau 38297 ST QUENTIN FALLAVIER  
Tel : (33) 04.74.94.15.90 Fax : (33) 04.74.95.62.08  
E.mail : sferaco@sferaco.fr

### SPECIFICATIONS :

- . All positions
- . Female/female
- . Brass

### USE :

- . For all common fluids
- . Max temperature Ts : 100°C
- . Max pressure Ps : see dimensions

### RANGE :

- Female/female hostaform Ref. 303 3/8" to 4"
- Female/female brass Ref. 305 3/8" to 4"

### MATERIALS :

N°	DESIGNATION	MATERIALS
1	Body	Brass EN 12165
2	Throttle 303	Hostaform
2	Throttle 305	Brass / stainless steel
3	Gasket	NBR
4	Spring	Stainless steel 304

### SIZE :

	DN	3/8"	1/2"	3/4"	1"	1" 1/4	1" 1/2	2"	2" 1/2	3"	4"
Ref. 303	L	27	29	37	45	56	63	78	103	121	155
	H	45	48	52	59	65	70	78	92	102	116
	F	8	11	12	13	14	15	17	18	20	22
	Ps	16	16	16	16	10	10	10	8	8	8
	Weight	0,09	0,1	0,155	0,225	0,35	0,47	0,71	1,26	1,81	3,1

	DN	3/8"	1/2"	3/4"	1"	1" 1/4	1" 1/2	2"	2" 1/2	3"	4"
Ref. 305	L	34,5	34,5	41,5	48	60,5	71	87	120	140	173
	H	54	57	64	75	82	93	100	120	140	158
	F	11	13	14	17	18	19	21	26	27	28
	Ps	25	25	25	25	18	18	18	12	12	12
	Weight	0,12	0,15	0,21	0,35	0,64	0,7	1,17	2,05	4,15	5,08

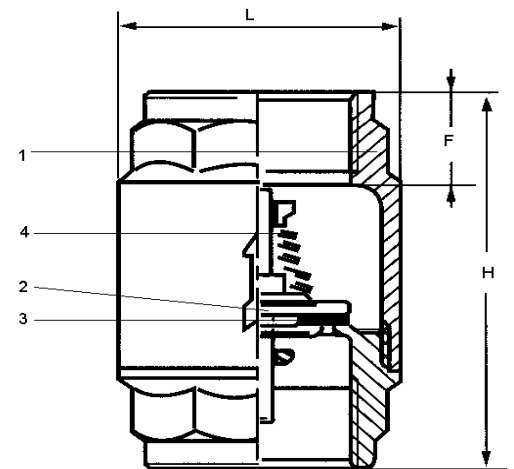
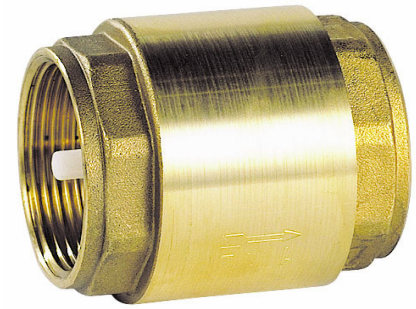

### STANDARDS :

- . French water agreement

N° (A.C.S.) N° 03 ACC LI008 pour 305

N° (A.C.S.) N° 05 ACC LY150 pour 303

### HEAD LOSS :

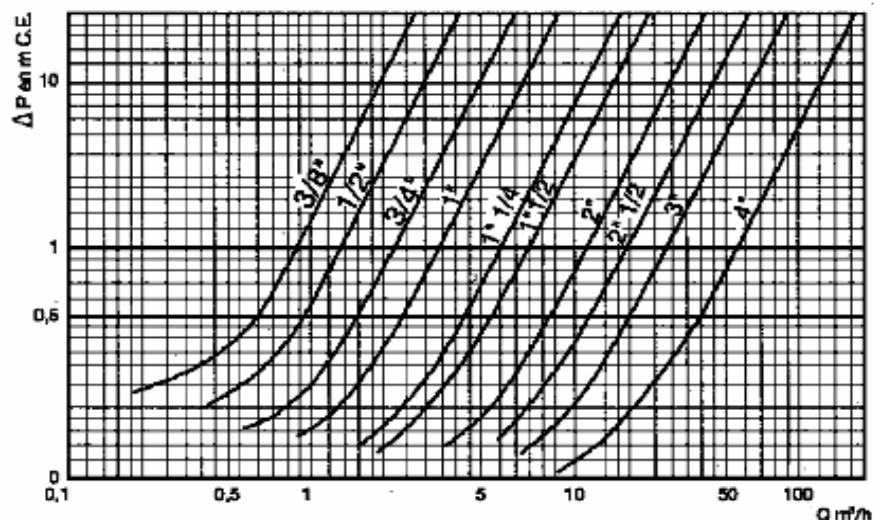

**ADVICE :** Our opinion and our advice are not guaranteed and SFERACO shall not be liable for the consequences of damages. The customer must check the right choice of the products with the real service conditions