

MONTAŻ Osadnik powinien być montowany w położeniu poziomym pokrywą w dół. Dopuszczalne jest położenie pionowe osadnika przy przepływie czynnika z góry na dół.	EINBAUHINWEISE Der Schmutzfänger ist in der waagerechten Lage zu montieren, Deckel nach unten. Es ist die vertikale Lage zulässig, wenn das Medium von oben nach unten fließt.	ASSEMBLING Strainer should be installed in horizontal position, bonnet down. The installation in vertical position is possible when the flow is also from up to down.
		

ZETKAMA Fabryka Armatury Przemysłowej S.A.
 ul. Śląska 24, 57-300 Kłodzko, Poland
 www.zetkama.com.pl

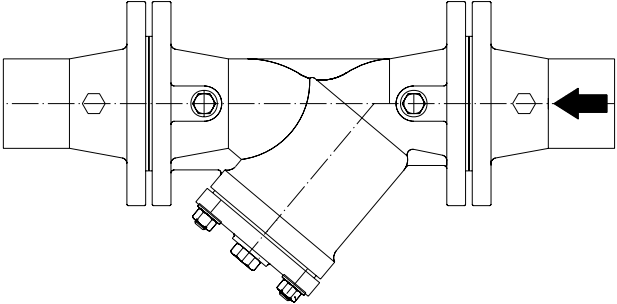
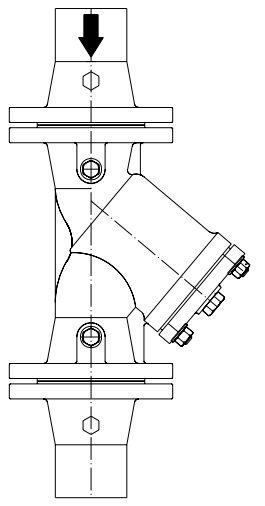

OSADNIK - FILTR SIATKOWY żeliwny, skośny	SCHRÄGSITZ-SCHMUTZFÄNGER mit Flanschanschlüssen, Y-typ	STRAINER with flanged ends, Y-type	
PN6 (0,6 MPa) DN 15 - 200	Max. temperatura pracy Max. Betriebstemperatur Max. working temperature	Fig. 821	
PN16 (1,6 MPa) DN 15 - 400			300 ⁰ C
PN25 (2,5 MPa) DN 15 - 250			350 ⁰ C
PN40 (4,0 MPa) DN 15 - 200			400 ⁰ C

ZASTOSOWANIE

Woda przemysłowa zimna i gorąca (w tym woda pitna), para wodna, czynniki obojętne

ZALETY

- wkład wykonany ze stali nierdzewnej,
- mocna konstrukcja wkładu,
- możliwość czyszczenia filtra bez demontażu,
- bez azbestu,
- bezpieczny ekologicznie.

ANWENDUNG

Kalt- und Heiß-Brauchwasser (auch Trinkwasser), Dampf, neutrale Flüssigkeiten.

VOORTEILE

- Sieb und Stützkorb aus Niro,
- feste Konstruktion von Stützkorb und Sieb,
- Reinigung erfolgt ohne Demontage,
- asbestfrei,
- umweltfreundlich.

APPLICATION

Industrial cold and hot water (also for drinking water), steam, neutral fluids.

ADVANTAGES

- screen made of stainless steel,
- strong construction of screen,
- cleaning of screen without disassembling,
- asbestos free,
- environment-friendly.

Ciężnienie - temperatura Druck - Temperatur Pressure - temperature									
DIN EN 1092-2: 1997									
EN-GJL-250		EN-GJS-500-7				GP240GH			
PN 6		PN 16		PN 16		PN 25		PN 40	
°C	bar	°C	bar	°C	bar	°C	bar	°C	bar
-10	6	-10	16	-10	16	-10	25	-20	40
120	6	120	16	120	16	120	25	150	40
150	5,4	150	14,4	150	15,2	150	23,8	200	35
180	5	180	13,4	200	14,4	200	22,5	300	28
200	4,8	200	12,8	250	12,8	250	20,0	400	21
230	4,4	230	11,8	300	11,2	300	17,5		
250	4,2	250	11,2	350	8,8	350	13,8		
300	3,6	300	9,6						

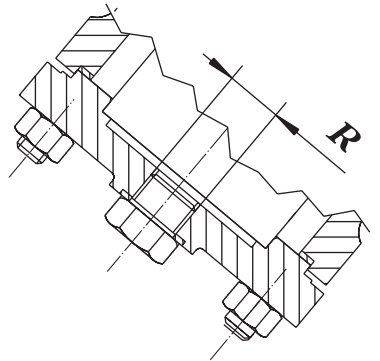

Korek spustowy
Entleerungsschraube
Emptying screw

Długość zabudowy Baulänge Face to face length	EN558-1 → 1 (DIN3202 → F1)
---	-------------------------------

Kolnierze Flansche Flanges	EN 1092 - 2
----------------------------------	-------------

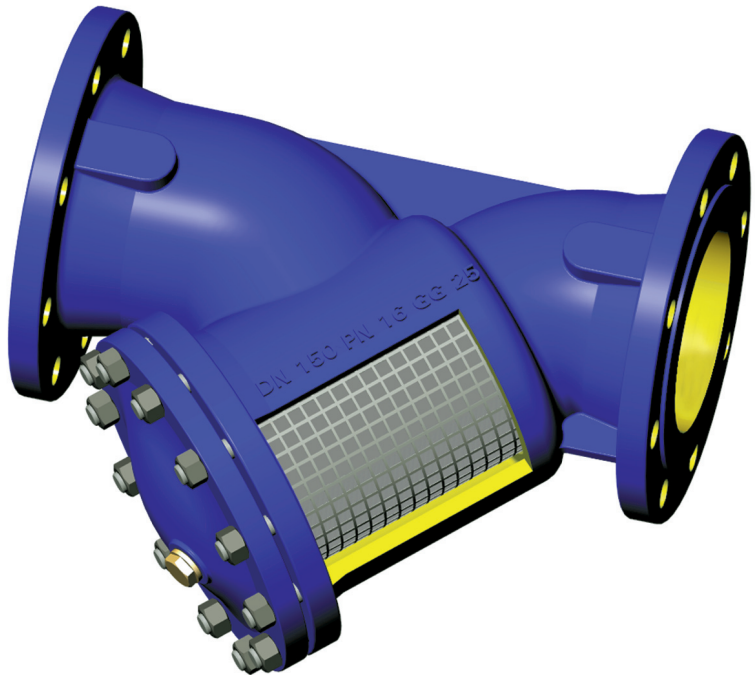

ZAMAWIANIE

W zamówieniu należy podać Fig. i DN.
 Informacje mają charakter ogólny.
 Szczegółowych informacji udziela dział Marketingu.

Fig. 821F - Armatura kompletna

Sekretariat tel. (0048) (074) 867 28 48
 865 21 00
 fax (0048) (074) 865 21 01
 e-mail: zetkama@zetkama.com.pl

BESTELLUNGEN

Bei Bestellungen sind Fig. und DN anzugeben.
 Es wurden allgemeine Informationen angegeben.
 Weitere Angaben werden von der Marketingabteilung mitgeteilt.

Fig. 821F - Komplementierte Armatur

Sprzedaż krajowa tel. (0048) (074) 865 21 52
 865 21 88
 fax (0048) (074) 865 21 98
 e-mail: spkraj@zetkama.com.pl

ORDERING

When ordering please specify: Fig. and DN.
 These data are for information only.
 Our marketing department provides you with detailed specifications.

Fig. 821F - Cooperation valves

Marketing tel. (0048) (074) 865 21 74
 fax (0048) (074) 865 21 98
 e-mail: marketing@zetkama.com.pl

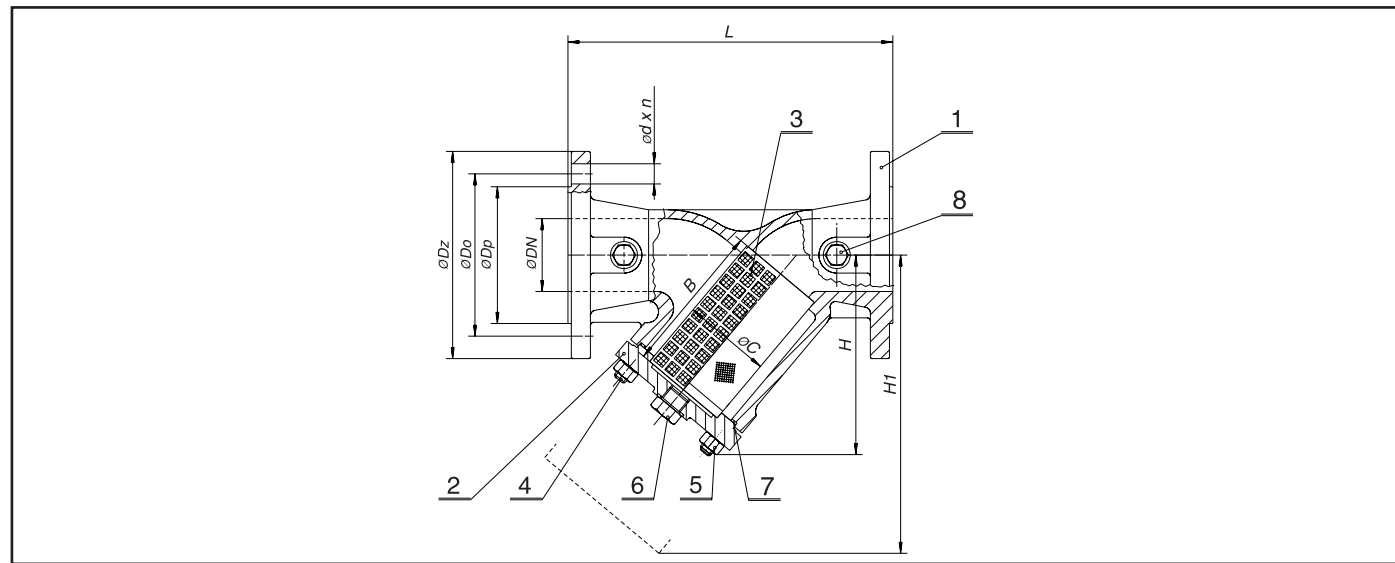

Fig. 821A	EN-GJL-250	PN 6	DN 15-200
Fig. 821A	EN-GJL-250	PN 16	DN 15-400
Fig. 821D	EN-GJS-500-7	PN 16	DN 15-300
Fig. 821D	EN-GJS-500-7	PN 25	DN 15-250
Fig. 821F	GP240GH	PN 40	DN 15-200
Kadlub + pokrywa / Gehäuse + Deckel / Body + bonnet			
A - EN-GJL-250		D - EN-GJS-500-7	
		F - GP240GH	

MATERIAŁY • WERKSTOFFE • MATERIALS		PN 6 PN 16	PN 16 PN 25	PN40
1.	Kadlub / Gehäuse / Body	EN-GJL-250	EN-GJS-500-7	GP240GH
2.	Pokrywa / Deckel / Bonnet			
3.	Wkład filtrujący / Schmutzfängersieb / Strainer screen	X5CrNi 18-10 1.4301		
4.	Śruby dwustronne / Stiftschrauben / Studs	8.8	A2-70	Ck 35
5.	Nakrętki / Sechskantmuttern / Hexagon nuts	8	A2-70	-
6.	Korek spustowy / Entleerungsschraube / Emptying screw	45 (C45) → ocynk./ verzinkt/ galvanizing		Ck 35
		A2		
7.	Uszczelka / Dichtung / Gasket	Graphit - CrNiSt		
8.*	Korek / Verschlusschraube / Plug	G1/4"	45 (C45) → ocynk./ verzinkt/ galvanizing	-
-	Uszczelki korków/Dichtung-Verschlusschraube/Plug's gaskets	A4(WNR-1.4571)		

* - na życzenie (za dopłatą) / auf Wunsch (Mehrpreis) / - on request (add. cost)

DN	L	PN 6				PN 16				PN 25				PN 40			
		Dz	Dp	Do	n x d	Dz	Dp	Do	n x d	Dz	Dp	Do	n x d	Dz	Dp	Do	n x d
mm																	
15	130	80	40	55	4 x 11	95	41	65	4 x 14	95	46	65	4 x 14	95	45	65	4 x 14
20	150	90	50	65	4 x 11	105	46	75	4 x 14	105	56	75	4 x 14	105	58	75	4 x 14
25	160	100	60	75	4 x 11	115	56	85	4 x 14	115	65	85	4 x 14	115	68	85	4 x 14
32	180	120	70	90	4 x 14	140	65	100	4 x 19	140	76	100	4 x 19	140	78	100	4 x 18
40	200	130	80	100	4 x 14	150	76	110	4 x 19	150	84	110	4 x 19	150	88	110	4 x 18
50	230	140	90	110	4 x 14	165	84	125	4 x 19	165	99	125	4 x 19	165	102	125	4 x 18
65	290	160	110	130	4 x 14	185	99	145	4 x 19	185	118	145	8 x 19	185	122	145	8 x 18
80	310	190	128	150	4 x 18	200	118	160	8 x 19	200	132	160	8 x 19	200	138	160	8 x 18
100	350	210	148	170	4 x 18	220	132	180	8 x 19	235	156	190	8 x 23	235	162	190	8 x 22
125	400	240	178	200	8 x 18	250	156	210	8 x 19	270	184	220	8 x 28	270	188	220	8 x 26
150	480	265	202	225	8 x 18	285	184	240	8 x 23	300	211	250	8 x 28	300	218	250	8 x 26
200	600	320	258	280	8 x 18	340	211	295	12 x 23	360	274	310	12 x 28	375	285	320	12 x 30
250	730	-	-	-	-	405	266	355	12 x 28	425	330	370	12 x 31	-	-	-	-
300	850	-	-	-	-	460	319	410	12 x 28	485	389	430	16 x 31	-	-	-	-
350	980	-	-	-	-	520	370	470	16 x 28	-	-	-	-	-	-	-	-
400	1100	-	-	-	-	580	429	525	16 x 31	-	-	-	-	-	-	-	-

Uwaga: 1. Materiał wg EN. Vermerk: 1. Material nach EN. Note: Material in accordance to EN.

WKŁAD FILTRUJĄCY / SCHMUTZFÄNGERSIEB / STRAINER SCREEN				
PN6, PN16, PN25				
Wkłady z siatki / Gittereinsatz / Screen cartridges				
	Oznaczenie	DN mm	Oczko siatki Maschenweite Mesh	Ilość oczek w cm ² Siebmaschen cm ² Meshs screen in cm ²
Wykonanie podstawowe Grundausführung Basic desing	F45	15 - 50	1,0	45
	F28	65 - 80	1,25	28
	F15	100 - 400	1,6	15
Wykonanie dodatkowe Zusätzliche Ausführung Additional design	F100	15 - 400	0,6	100
	F200	15 - 400	0,5	204
	F300	15 - 400	0,4	280
	F400	15 - 400	0,32	370
	F600	15 - 400	0,25	625
Wkład z blachy / Blecheinsatz / Tin plate cartridge				
Wykonanie specjalne Sonderausführung Special design	F1.0	15 - 125	1,0	30
	F1.6	150 - 300	1,6	13
	F3.1	350 - 400	3,1	3
PN40				
Wykonanie podstawowe Grundausführung / Basic desing	F100	15 - 65	0,6	100
	F1.0	80 - 200	1,0	30

OPCJA F.821 / OPTION F.821 / OPTIONAL F.821

Fig.821.M

Wkład Magnetyczny / Magnetischeinsatz / Magnetic cartridge
X5CrNi 18-10 1.4301

OPCJA F.821 / OPTION F.821 / OPTIONAL F.821

Fig.821.E

Dla wody pitnej / Für Trinkwasser / For drinking water

Farba epoksydowa Epoxyfarbe Epoxy paint	RAL 5010 RAL 5017
Śruby dwustronne, nakrętki Stiftschrauben, Sechskantmuttern Stud-bolds, hexagon nuts	Stal nierdz. Niro Stainless steel
	ocynkowane verzinkt zinc coated
Korek spustowy Entleerungsschraube Emptying screw	Stal nierdz. Niro Stainless steel
	C45 → ocynk./ verzinkt/ galvanzig

Atest / Attest / Certificate - National Institute of Hygiene Poland

DN	R	PN6, PN16, PN25				PN40	PN6	PN16	PN25	PN40	kv	DN
		B	C	H	H1	H						
mm												
kg												
15	G 3/8"	56	23	90	135	70	2,2	2,6	2,6	2,7	5,7	15
20		68	28	100	150	80	2,8	3,0	3,0	3,6	10,4	20
25		82	36	115	180	88	3,9	4,3	4,3	4,5	16,4	25
32		98	42	135	215	100	5,7	6,8	6,8	6,3	27,3	32
40		114	50	150	240	125	7,3	8,8	9,0	8,7	42	40
50	G 1/2"	119	61,5	160	250	140	8,4	11,0	10,7	11,0	64,7	50
65		134	78,5	180	285	170	13,5	16,8	16,1	15,0	96	65
80		149	89,5	215	330	190	17,7	19,5	18,2	22,0	149	80
100		169	109,5	235	365	225	25,3	34,0	32,5	31,5	223	100
125		199	137,5	280	425	260	37,5	42,5	39,2	46,0	347	125
150		224	160	320	480	320	49,0	56,0	52,2	71,0	480	150
200		284	210	405	610	420	98,0	110,0	102,7	134,5	853	200
250		434	258	540	915	-	-	165,0	170	-	1104	250
300		555	308	680	1110	-	-	285,0	290	-	1450	300
350		G 1"	640	365	755	1200	-	-	373,0	-	1800,0	350
400	695		415	835	1320	-	-	461,0	-	2200,0	400	

R - Korek spustowy / Entleerungsschraube / Emptying screw